

Bombierung:

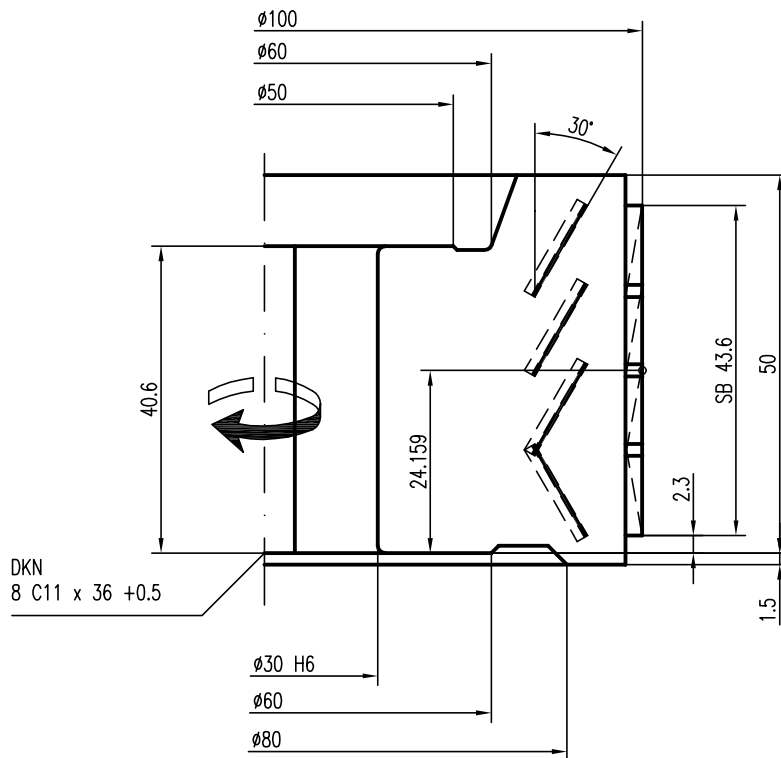
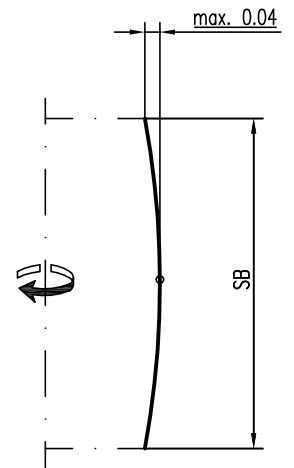

Z 3 (4 Zahnreihen)

MEC (mech. Vorschub)

n max. 12000 1/min

SCHUTZVERMERK DIN 34-1-D	ERST	DATUM 02.03.09	NAME erp		WERK OBER- KOCHEN D-73447	Ersatz für Alte Leitz-Nr.
	Fertigungstoleranzen nach LEITZ - Werknorm	GEPR	DET			erp
Werkstoff DP	DP-Fugemesserkopf PRO DP:100x43.6x30DKN Z3 LL - Low Noise				Ident-Nr. 90885	
Maßstab 1 : 1						

Bombierung:

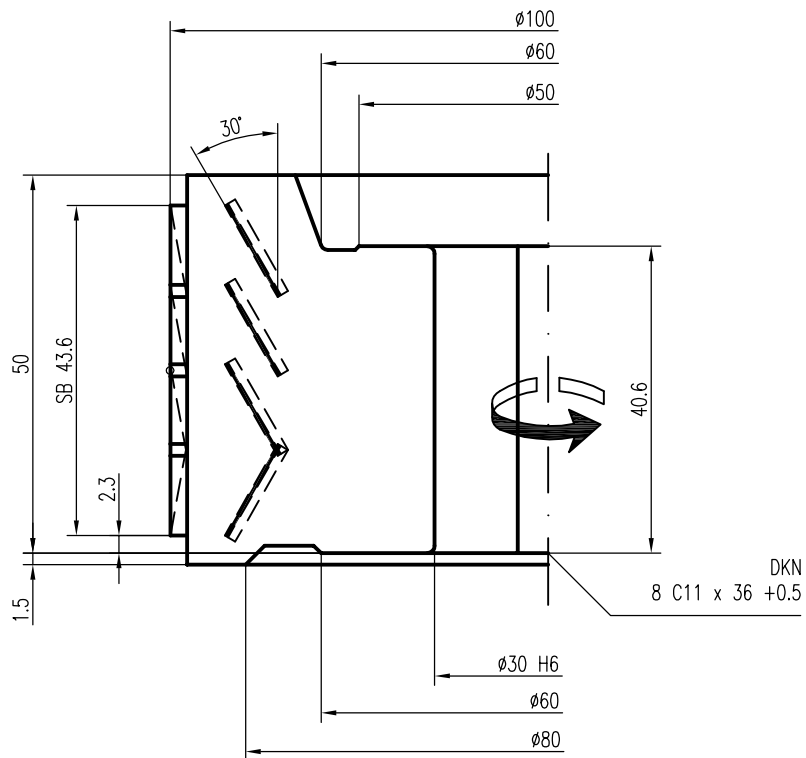
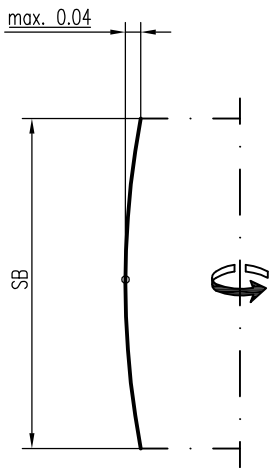

Z 3 (4 Zahnreihen)

MEC (mech. Vorschub)

n max. 12000 1/min

SCHUTZVERMERK DIN 34-1-D	ERST	DATUM 02.03.09	NAME erp		WERK OBER- KOCHEN D-73447	Ersatz für Alte Leitz-Nr.
	GEPR	02.03.09	erp			Artikel-Nr. WM 230-2 01
Fertigungstoleranzen nach LEITZ - Werknorm	DET					Ident-Nr. 90886
Werkstoff DP	DP-Fügemesserkopf PRO DP:100x43.6x30DKN Z3 RL - Low Noise					
Maßstab 1 : 1						